

## Bar Graph Temperature Controllers

### ■ Features

- High speed sampling of 50ms and  $\pm 0.3\%$  display accuracy
- Enable to check control output operation amount by adopting bar graph
- Simultaneous heating/cooling control and automatic/manual control for high performance control
- Selection function of current output or SSR drive output
- Parameter setting available via PC (USB and RS485 communication)
  - Free device comprehensive management program (DAQMaster)
    - ※ Communication converter sold separately: SCM-US(USB/Serial converter), SCM-38I(RS232C/RS485 converter) SCM-US48I(USB/RS485 converter)
- Multi-SV (max. 4) function (select via digital input terminal)
- Heater break alarm
  - ※ CT sold separately: CSTC-E80LN, CSTC-E200LN, CSTS-E80PP
- Small size (rear length: 60mm)
- Multi input/multi range



 Please read "Safety Considerations" in the instruction manual before using.



### ■ Manuals

- For the detail information and instructions, please refer to user manual and user manual for communication, and be sure to follow cautions written in the technical descriptions (catalog, website).  
Visit our website ([www.autonics.com](http://www.autonics.com)) to download manuals.
- The user manual includes product specifications, functions, and operations.
- The user manual for communication includes information about Modbus RTU protocol, and Modbus mapping table.

### ■ Comprehensive Device Management Program (DAQMaster)

DAQMaster is the comprehensive device management program to set parameters and manage monitoring data and user group, parameter mask which are the dedicated function of KPN.

Visit our website ([www.autonics.com](http://www.autonics.com)) to download user manual and comprehensive device management program.

< Computer specification for using software >

Item	Minimum requirements
System	IBM PC compatible computer with Intel Pentium III or above
Operations	Microsoft Windows 98/NT/XP/Vista/7/8/10
Memory	256MB+
Hard disk	1GB+ of available hard disk space
VGA	Resolution: 1024×768 or higher
Others	RS-232 serial port (9-pin), USB port

< DAQMaster screen >





# Bar Graph Temperature Controllers

## ■ Specifications

Series		KPN52□□	KPN53□□	KPN55□□
Power supply	100-240VAC~ 50/60Hz			
Allowable voltage range	90 to 110% of rated voltage			
Power consumption	Max. 15VA			
Display method	7-segment (red, green), control bar graph: red, green			
Character size	PV (W×H)	8.5×17.0mm	7.0×14.6mm	11.0×22.0mm
	SV (W×H)	6.0×12.0mm	6.0×12.0mm	6.0×12.0mm
Input type	RTD	JPt100Ω, DPt100Ω, DPt50Ω, Cu100Ω, Cu50Ω, Nikel120Ω (6 types)		
	TC	K, J, E, T, L, N, U, R, S, B, C, G, PLII (13 types)		
	Analog	· Voltage: 0-100 mV, 0-5 V, 1-5 V, 0-10 V (4 types) · Current: 0-20mA, 4-20mA (2 types)		
Display accuracy	RTD	· At room temperature (23±5°C): (PV ±0.3% or ±1°C, select the higher one) ±1-digit *1		
	TC	· Out of room temperature range: (PV ±0.5% or ±2°C, select the higher one) ±1-digit		
	Analog	At room temperature (23±5°C): ±0.3% F.S.±1-digit, out of room temperature range: ±0.5% F.S.±1-digit		
	CT input	±5% F.S.±1-digit		
Control output	Relay	OUT1, OUT2: 250VAC~ 5A 1a		
	SSR	Max. 11VDC---±2V 20mA		
	Current	0-20mA or 4-20mA selectable (max. load 500Ω)		
Alarm output	Relay	AL1, AL2, AL3: 250VAC~ 3A 1a		
Option output	Transmission	4-20mA (load max. 600Ω, output accuracy: ±0.3% F.S.±1-digit)		
	Communication	RS485 communication output (modbus RTU method)		
Option input	CT	0.0-50.0A (primary heater current value measuring range) ※CT ratio is 1/1000		
	Remote SV	1-5VDC--- or 4-20mA (current input: using external resistance 250Ω)		
	Digital input	· Contact input: ON - max. 2kΩ, OFF - min. 90kΩ · Non-contact input: ON - residual voltage max. 1.0V, OFF - leakage current max. 0.1mA		
Control type	Heating, Cooling Heating&Cooling	ON/OFF control, P, PI, PD, PID control		
Hysteresis	· Thermocouple/RTD: 1 to 100°C/°F (0.1 to 100.0°C/°F) variable · Analog: 1 to 100-digit			
Proportional band (P)	0.1 to 999.9°C(0.1 to 999.9%)			
Integral time (I)	0 to 9999 sec			
Derivative time (D)	0 to 9999 sec			
Control period (T)	Relay output, SSR drive output: 0.1 to 120.0 sec Current output + SSR drive output: 1.0 to 120.0 sec			
Manual reset value	0.0 to 100.0%			
Sampling period	50ms			
Dielectric strength	2000VAC 50/60Hz for 1 min (between input terminal and power source terminal)			
Vibration	0.75mm amplitude at frequency of 5 to 55Hz (for 1 min) in each X, Y, Z direction for 2 hours			
Relay life cycle	Mechanical	Over 10,000,000 operations		
	Electrical	Over 100,000 operations (250VAC 3A resistance load)		
Insulation resistance	Over 100MΩ (at 500VDC megger)			
Noise immunity	Square shaped noise by noise simulator (pulse width 1μs) ±2kV R-phase, S-phase			
Memory retention	Approx. 10 years (when using non-volatile semiconductor memory type)			
Environment	Ambient temp.	-10 to 50°C, storage: -20 to 60°C		
	Ambient humidity	35 to 85%RH, storage: 35 to 85%RH		
Protection	IP65 (front panel, IEC standard)			
Insulation type	Double insulation or reinforced insulation (mark: □, dielectric strength between the measuring input part and the power part: 1kV)			
Approval	CE			
Weight*2	Approx. 230g (approx. 160g)		Approx. 316g (approx. 220g)	

\*1. ① At room temperature (23°C±5°C)

- TC K, J, T, N, E type, below -100°C / L, U, PLII, RTD Cu50, DPt50: (PV ±0.3% or ±2°C, select the higher one) ±1-digit
- TC C, G and R, S type, below 200°C: (PV ±0.3% or ±3°C, select the higher one) ±1-digit
- TC B type, below 400°C, there is no accuracy standards.

② Out of room temperature range

- RTD Cu50, DPt50: (PV 0.5% or ±3°C, select the higher one) ±1-digit
- RTD R, S, B, C, G: (PV ±0.5% or ±10°C, select the higher one) ±1-digit
- Other sensors: below -100°C, within ±5°C

\*2. The weight includes packaging. The weight in parenthesis is for unit only.

※ Environment resistance is rated at no freezing or condensation.

# KPN Series

## Input Type and Range

Input type		Demical point	display	Input range (°C)	Input range (°F)
Thermocouple	K(CA)	1	ℓℓℓ 1	-200 to 1350	-328 to 2463
		0.1	ℓℓℓ.2	-199.9 to 999.9	-199.9 to 999.9
	J(IC)	1	ℓℓ.ℓ 1	-200 to 800	-328 to 1472
		0.1	ℓℓ.ℓ.2	-199.9 to 800.0	-199.9 to 999.9
	E(CR)	1	ℓℓ.ℓ 1	-200 to 800	-328 to 1472
		0.1	ℓℓ.ℓ.2	-199.9 to 800.0	-199.9 to 999.9
	T(CC)	1	ℓℓ.ℓ 1	-200 to 400	-328 to 752
		0.1	ℓℓ.ℓ.2	-199.9 to 400.0	-199.9 to 752.0
	B(PR)	1	ℓℓ - b	0 to 1800	32 to 3272
	R(PR)	1	ℓℓ - r	0 to 1750	32 to 3182
	S(PR)	1	ℓℓ - s	0 to 1750	32 to 3182
	N(NN)	1	ℓℓ - n	-200 to 1300	-328 to 2372
	C(TT)*1	1	ℓℓ - ℓ	0 to 2300	32 to 4172
	G(TT)*2	1	ℓℓ - G	0 to 2300	32 to 4172
	L(IC)	1	ℓℓ.ℓ 1	-200 to 900	-328 to 1652
0.1		ℓℓ.ℓ.2	-199.9 to 900.0	-199.9 to 999.9	
U(CC)	1	ℓℓ.ℓ 1	-200 to 400	-328 to 752	
	0.1	ℓℓ.ℓ.2	-199.9 to 400.0	-199.9 to 752.0	
Platine II	1	ℓℓ - P	0 to 1390	32 to 2534	
RTD	Cu50Ω	0.1	ℓℓ.50	-199.9 to 200.0	-199.9 to 392.0
	Cu100Ω	0.1	ℓℓ.10	-199.9 to 200.0	-199.9 to 392.0
	JPt100Ω	1	ℓPℓ. 1	-200 to 650	-328 to 1202
		0.1	ℓPℓ.2	-199.9 to 650.0	-199.9 to 999.9
	DPt50Ω	0.1	dPℓ.5	-199.9 to 650.0	-199.9 to 999.9
		1	dPℓ. 1	-200 to 650	-328 to 1202
	0.1	dPℓ.2	-199.9 to 650.0	-199.9 to 999.9	
Nickel120Ω	1	nℓ. 12	-80 to 200	-112 to 392	
Analog	0 - 10V		R - ℓ 1	-1999 to 9999 (display range depends on the decimal point position )	
	0 - 5V		R - ℓ.2		
	1 - 5V		R - ℓ.3		
	0 - 100mV		R.ℓℓ 1		
	0 - 20mA		R.ℓℓ R 1		
4 - 20mA		R.ℓℓ R.2			

※ 1: C(TT): Same as existing W5(TT) type sensor.

※ 2: G(TT): Same as existing W(TT) type sensor.

# Bar Graph Temperature Controllers

## Dimensions

(unit:mm)

### • KPN52□□

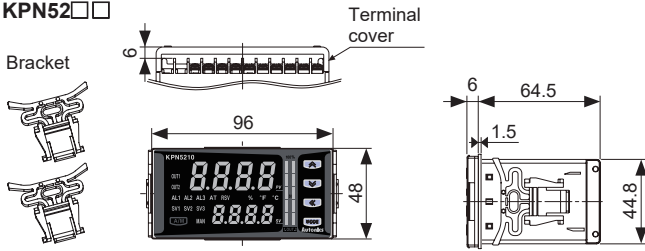

### • Panel cut-out

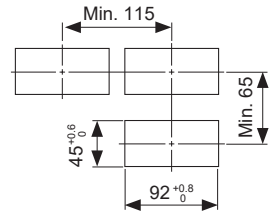

### • KPN53□□

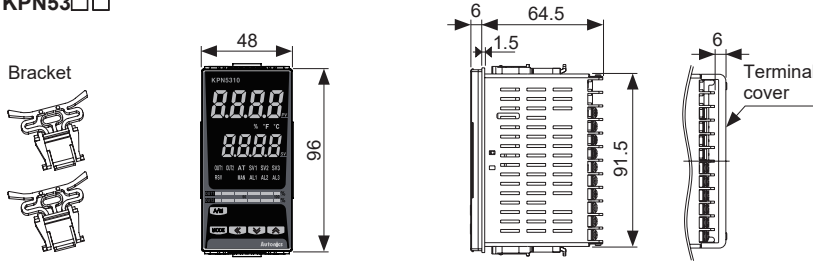

### • Panel cut-out

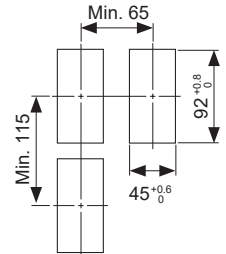

### • KPN55□□

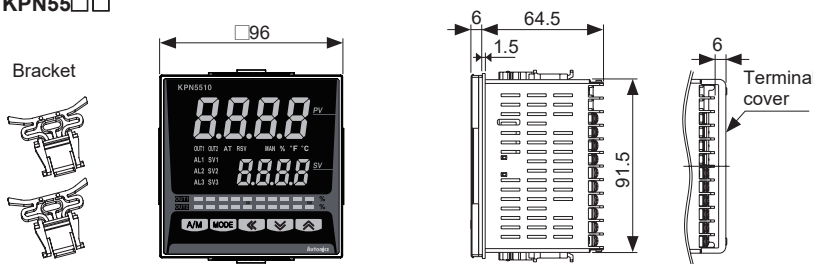

### • Panel cut-out

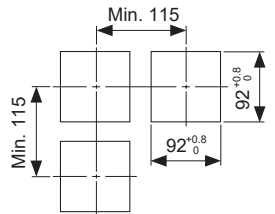

- Terminal cover (sold separately)
- RHA-COVER (48×96 mm size)

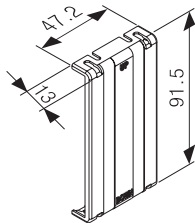

- RLA-COVER (96×96 mm size)

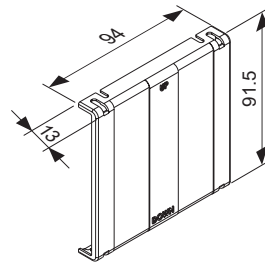

## Sold Separately

### ◎ Communication converter

- **SCM-WF48** (Wi-Fi to RS485-USB wireless communication converter)
- **SCM-US48I** (USB to RS485 converter)
- **SCM-38I** (RS232C to RS485 converter)
- **SCM-US** (USB to Serial converter)



# KPN Series

## ■ Sold Separately

### ◎ Current transformer (CT)

#### • CSTC-E80LN

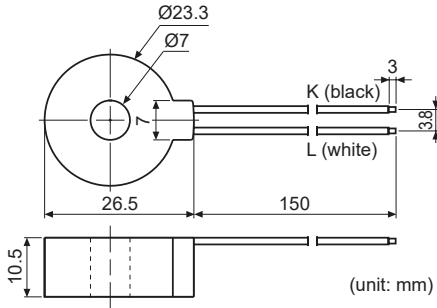

#### • CSTC-E200LN

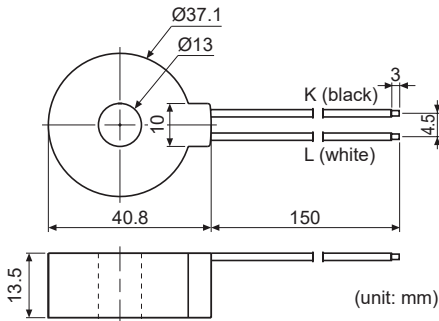

#### • CSTS-E80PP

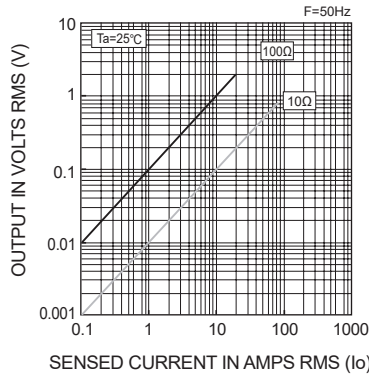
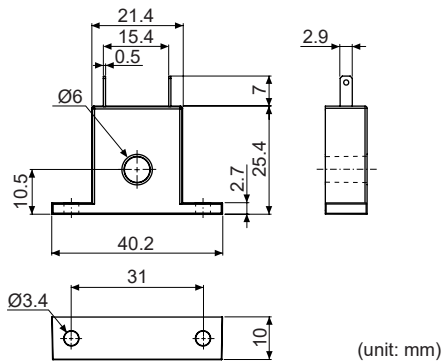

- Max. load current: 80A (50/60Hz)
- ※Max. load current for KPN Series is 50A.
- Current ratio: 1/1000
- Wire wounded resistance: 31Ω±10%

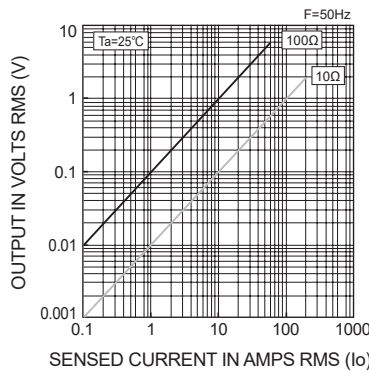

- Max. load current: 200A (50/60Hz)
- ※Max. load current for KPN Series is 50A.
- Current ratio: 1/1000
- Wire wounded resistance: 20Ω±10%

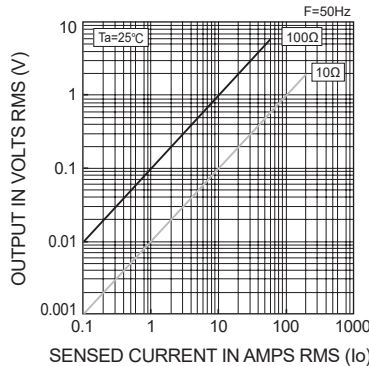

- Max. load current: 80A (50/60Hz)
- ※Max. load current for KPN Series is 50A.
- Current ratio: 1/1000
- Wire wounded resistance 31Ω±10%

※Do not supply primary current in case that CT output is open. High voltage will be generated in CT output.  
 ※The current for above CTs is 50A same but inner hole sizes are different. Please use this for your environment.

# Bar Graph Temperature Controllers

## Unit Description

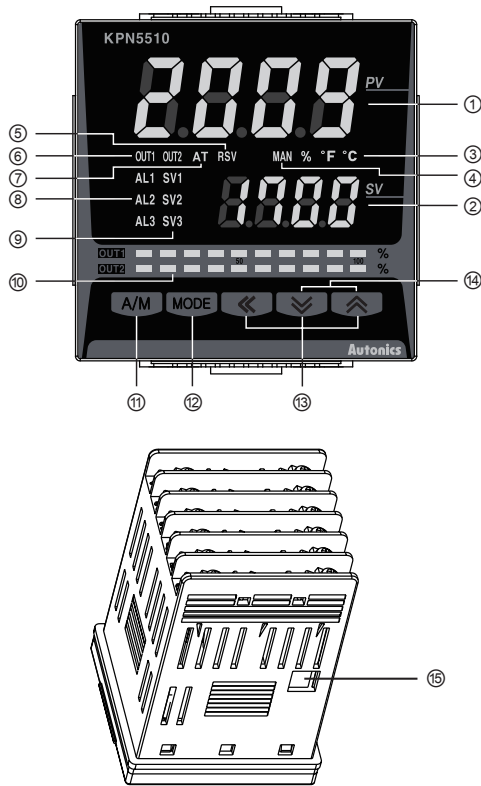

- ① Present value (PV) display part
  - RUN mode: Displays currently measured value (PV).
  - Set mode: Displays the parameters.
- ② Set value (SV) display part
  - RUN mode: Displays the set value (SV).
  - Set mode: Displays the set value of the parameter.
- ③ Unit (°C/°F/%) indicator: Displays the unit set at display unit [ dU n t ] in parameter 3 group.
- ④ Manual control indicator: Turns ON during manual controlling.
- ⑤ Remote SV control indicator: Turns ON during remote SV controlling.
- ⑥ Control output (OUT1, OUT2) indicator: Turns ON when the control output is ON.
  - ※Using current output, in case that for manual control MV is 0.0%, the control output indicator turns OFF but the other cases it turns ON always. In case that for auto control MV is over 3.0%, it turns ON and the MV is below 2.0%, it turns OFF.
- ⑦ Auto tuning indicator: Flashes by 1 sec when executing auto tuning.
- ⑧ Alarm output (AL1, AL2, AL3) indicator: Turns ON when the alarm output is ON.
- ⑨ Multi SV indicator: The SV 1 to 3 indicator turns ON when using multi SV function.
- ⑩ Bar graph for control output: Displays control output MV as bar graph.
  - KPN5□00 as 1 output type has one bar graph (OUT1), and the KPN5□1□ as 2 output type has two bar graphs (OUT1, OUT2).

- ⑪ **A/M** key: Used when switching auto control to manual control.
  - ⑫ **MODE** key: Used when entering parameter setting group, returning to RUN mode, moving parameter, saving the set value.
  - ⑬ **←, ↓, ↑** key: Used when entering the set value changing mode and moving or changing up/down digit.
  - ⑭ Digital input key: When pressing the **↓** + **↑** keys for 3 sec at the same time, it operates the function (RUN/STOP, alarm clear, auto-tuning) set at digital input key [ d i - t ] in parameter 5 group.
  - ⑮ PC loader port: It is the PC loader port for serial communication to set and monitor parameters by PC. Use this port for connection SCM-US (USB to serial convertor).
- ※ Display part is different by options.

## Set Value (SV) Setting

You can set the temperature to control with the **←, ↓, ↑** keys.

Setting range is within SV low-limit value [ L - 5 u ] to SV high-limit value [ H - 5 u ].

※ E.g.) In case of changing set temperature from 210 °C to 250 °C

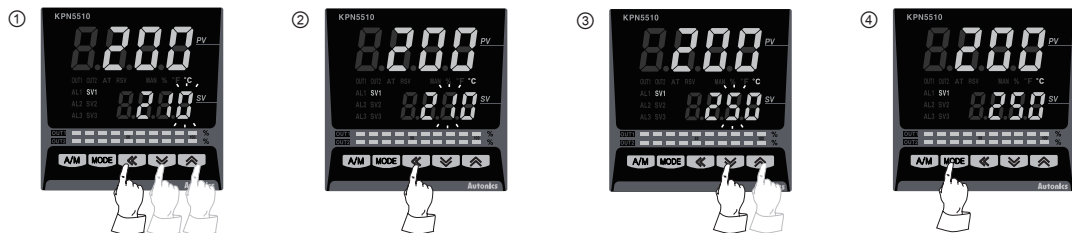

Press any key among the **←, ↓, ↑** in RUN mode to enter into SV setting mode. Last digit (10<sup>0</sup>-digit) on SV display part flashes.

Press the **←** key to move digit. (10<sup>0</sup>→10<sup>1</sup>→10<sup>2</sup>→10<sup>3</sup>→10<sup>0</sup>)

Press the **↓** or **↑** key to raise or lower the setting value. (1 → 5)

Press the **MODE** key to save the setting value. If there is no additional key operations in 3 sec, the changed SV is automatically saved.

# KPN Series

## Parameter Groups

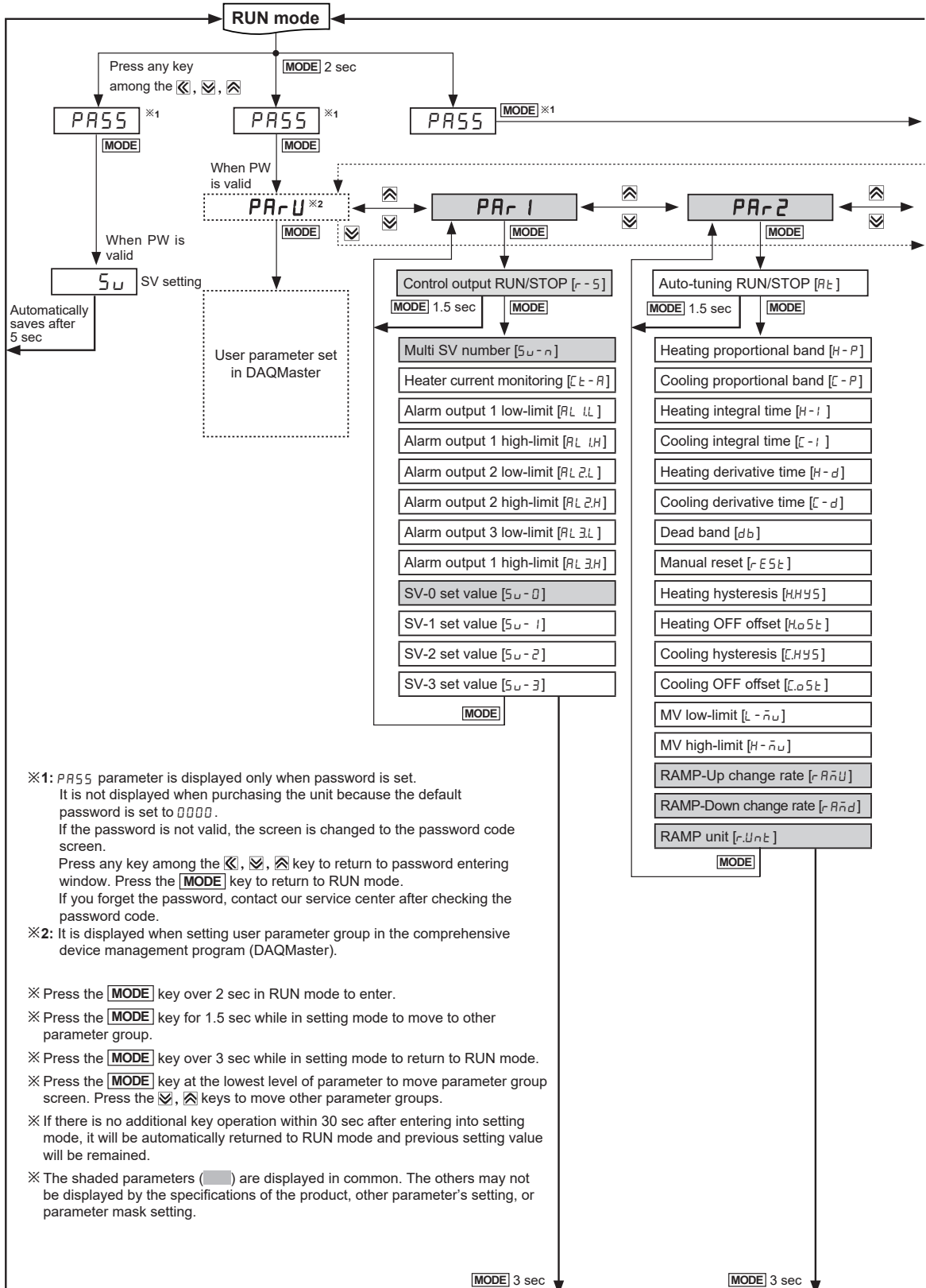

- ※1: **PASS** parameter is displayed only when password is set. It is not displayed when purchasing the unit because the default password is set to 0000. If the password is not valid, the screen is changed to the password code screen. Press any key among the  $\leftarrow$ ,  $\checkmark$ ,  $\rightarrow$  key to return to password entering window. Press the **MODE** key to return to RUN mode. If you forget the password, contact our service center after checking the password code.
- ※2: It is displayed when setting user parameter group in the comprehensive device management program (DAQMaster).

- ※ Press the **MODE** key over 2 sec in RUN mode to enter.
- ※ Press the **MODE** key for 1.5 sec while in setting mode to move to other parameter group.
- ※ Press the **MODE** key over 3 sec while in setting mode to return to RUN mode.
- ※ Press the **MODE** key at the lowest level of parameter to move parameter group screen. Press the  $\checkmark$ ,  $\rightarrow$  keys to move other parameter groups.
- ※ If there is no additional key operation within 30 sec after entering into setting mode, it will be automatically returned to RUN mode and previous setting value will be remained.
- ※ The shaded parameters (■) are displayed in common. The others may not be displayed by the specifications of the product, other parameter's setting, or parameter mask setting.

# Bar Graph Temperature Controllers

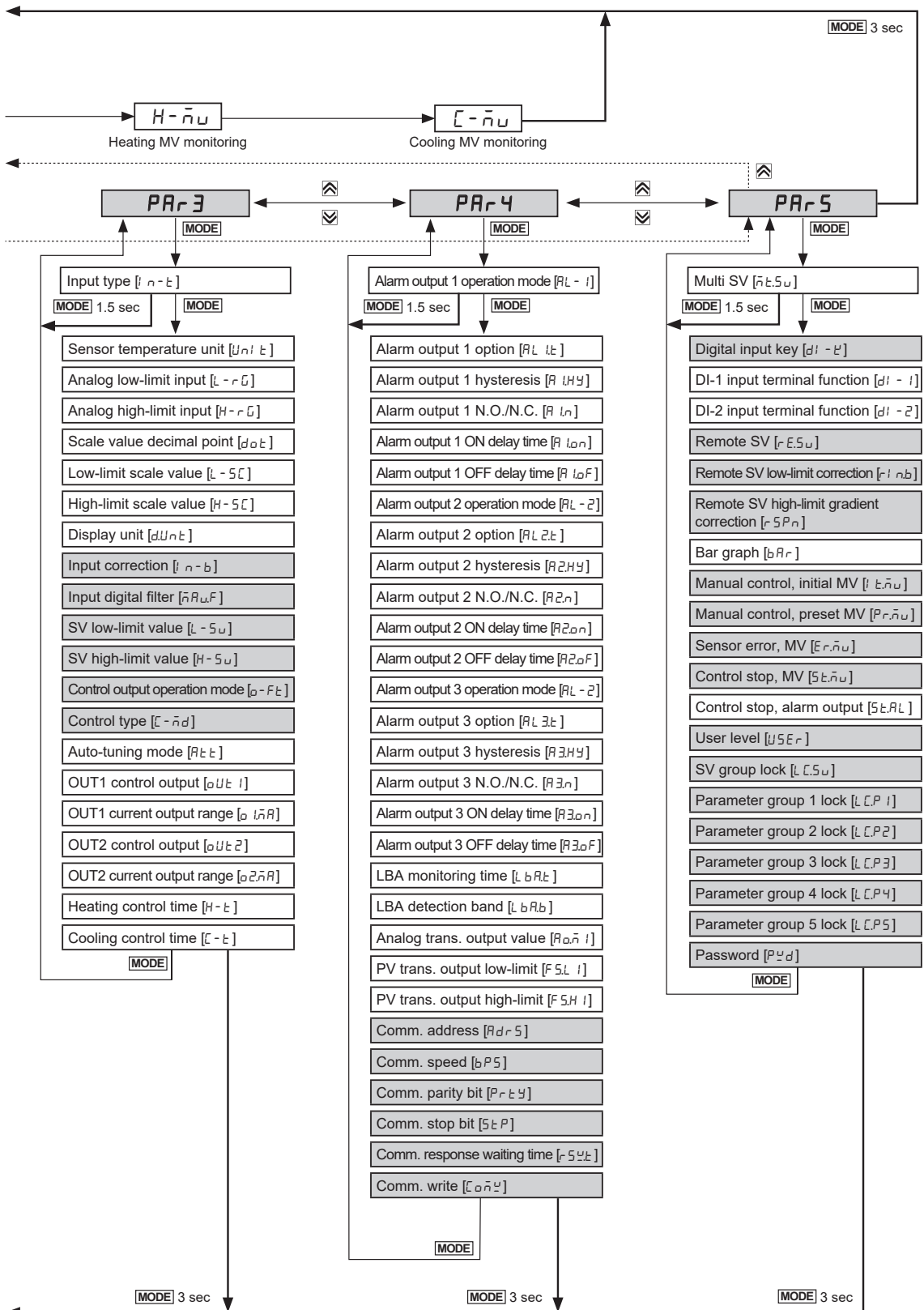

## Parameter 1 Group

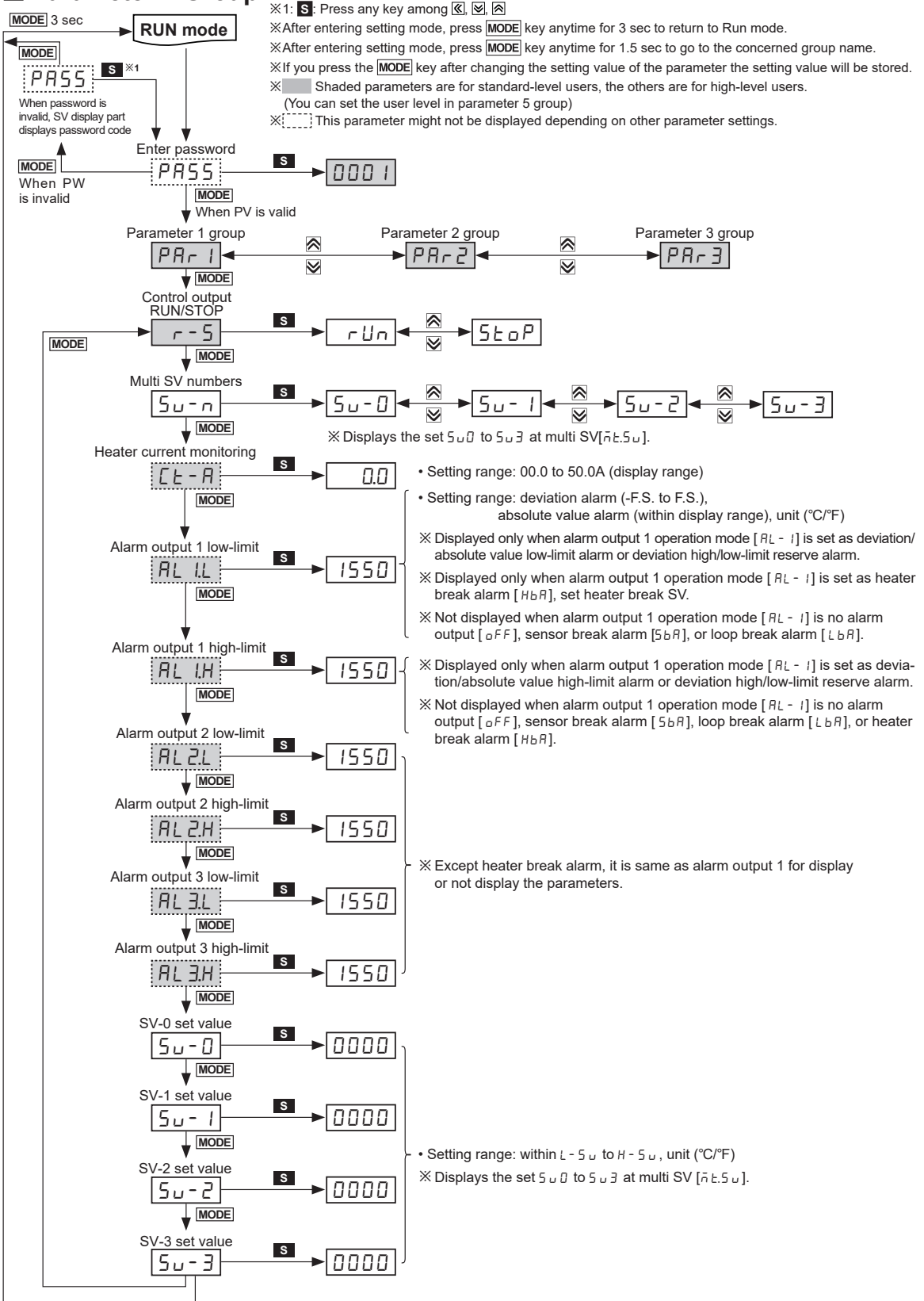

# Bar Graph Temperature Controllers

## Parameter 2 Group

- ※1: **S**: Press any key among  $\left[ \leftarrow \right]$ ,  $\left[ \rightarrow \right]$ ,  $\left[ \text{MODE} \right]$
- ※After entering setting mode, press  $\left[ \text{MODE} \right]$  key anytime for 3 sec to return to Run mode.
- ※After entering setting mode, press  $\left[ \text{MODE} \right]$  key anytime for 1.5 sec to go to the concerned group name.
- ※If you press the  $\left[ \text{MODE} \right]$  key after changing the setting value of the parameter the setting value will be stored.
- ※    Shaded parameters are for standard-level users, the others are for high-level users.
- ※ (You can set the user level in parameter 5 group)
- ※    This parameter might not be displayed depending on other parameter settings.

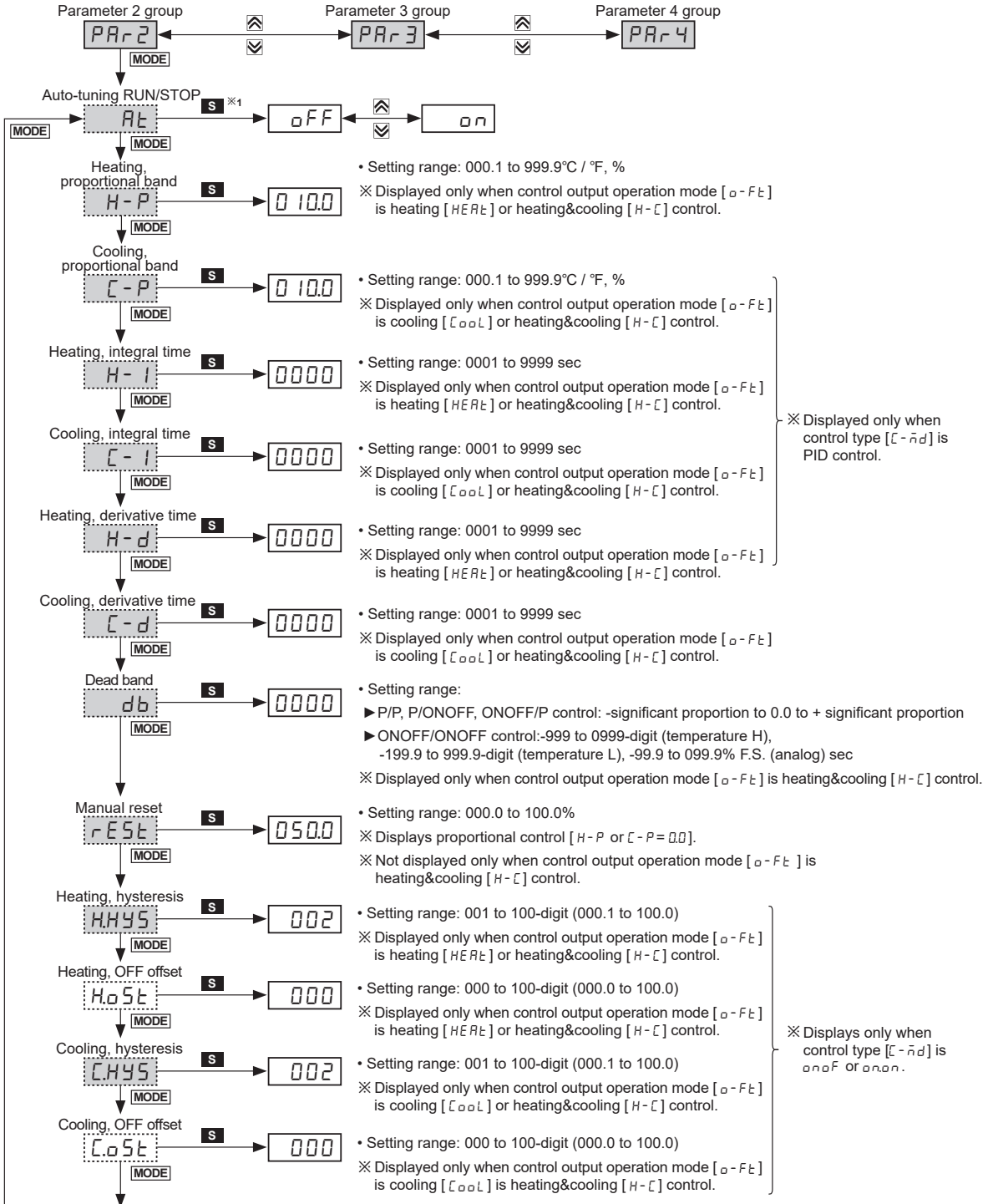

# KPN Series

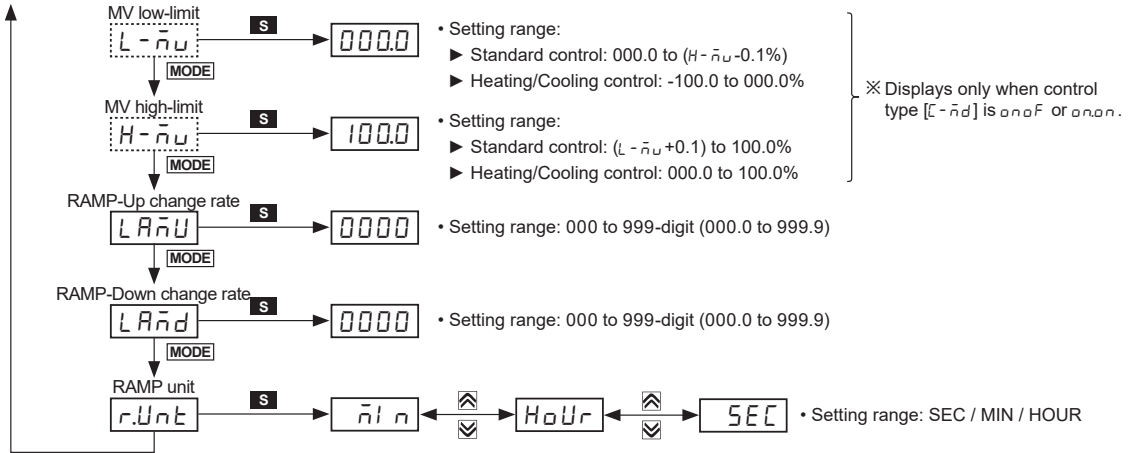

## Parameter 3 Group

- ※1: [S]: Press any key among [K], [M], [N]
- ※After entering setting mode, press [MODE] key anytime for 3 sec to return to Run mode.
- ※After entering setting mode, press [MODE] key anytime for 1.5 sec to go to the concerned group name.
- ※If you press the [MODE] key after changing the setting value of the parameter the setting value will be stored.
- ※ Shaded parameters are for standard-level users, the others are for high-level users.
- (You can set the user level in parameter 5 group)
- ※[ ]: This parameter might not be displayed depending on other parameter settings.

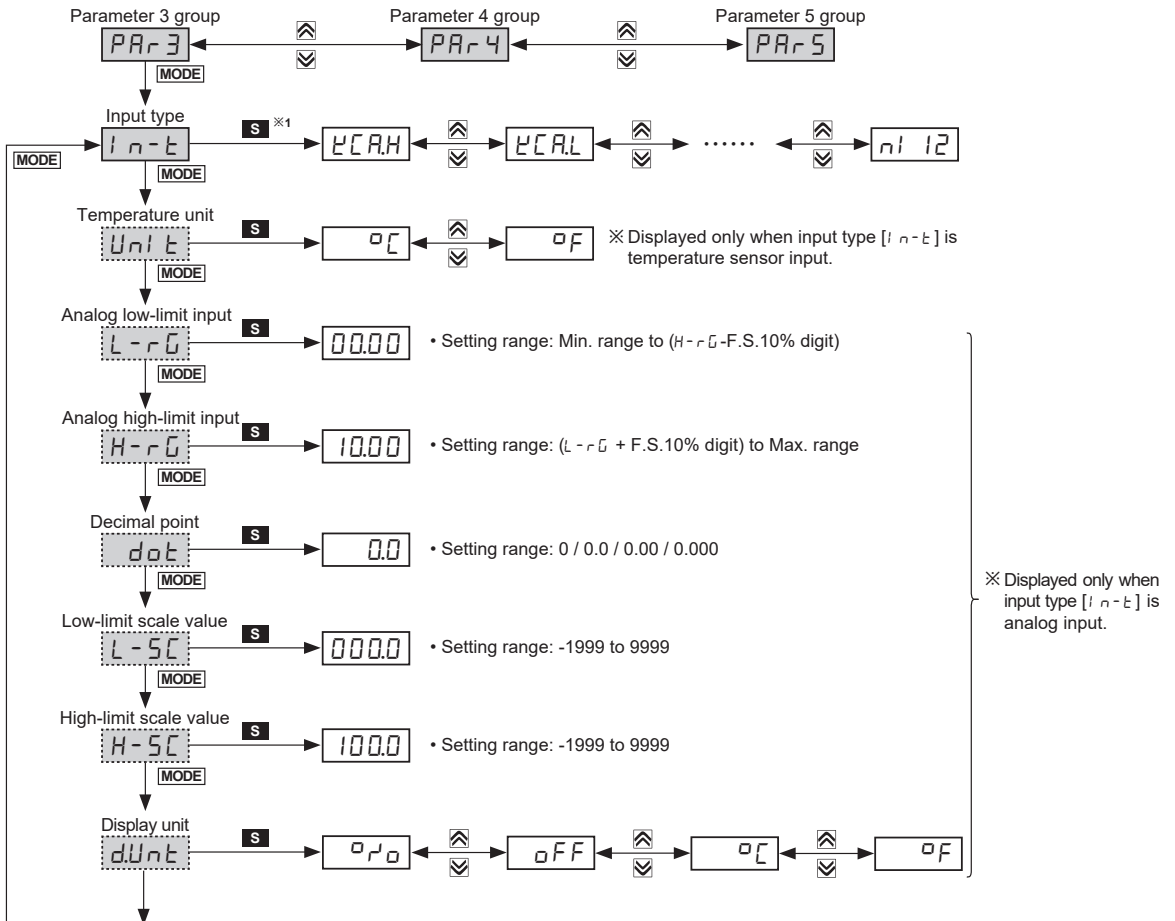

# Bar Graph Temperature Controllers

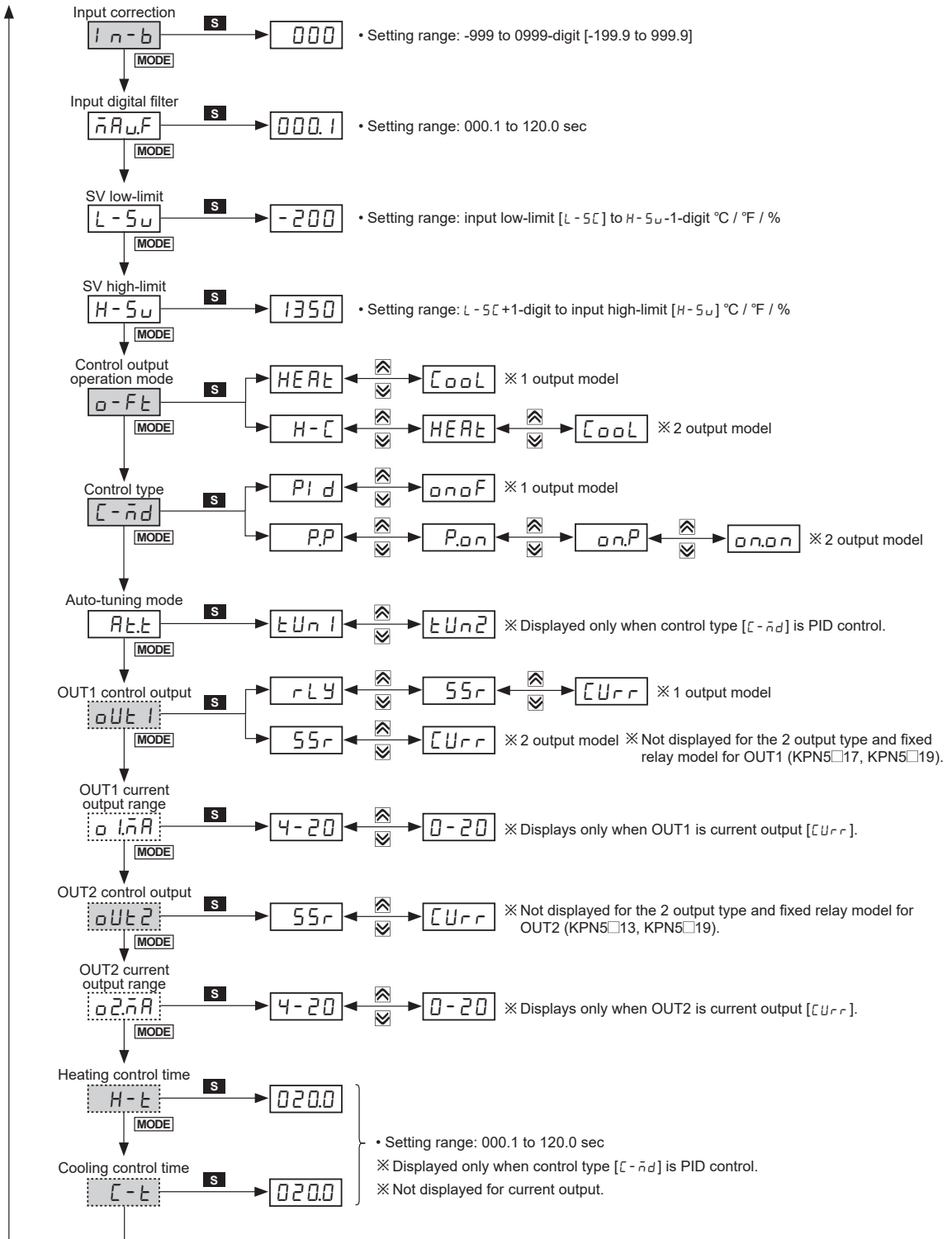

# KPN Series

## Parameter 4 Group

- ※1: **S**: Press any key among  $\leftarrow$ ,  $\rightarrow$ ,  $\uparrow$ ,  $\downarrow$
- ※After entering setting mode, press **MODE** key anytime for 3 sec to return to Run mode.
- ※After entering setting mode, press **MODE** key anytime for 1.5 sec to go to the concerned group name.
- ※If you press the **MODE** key after changing the setting value of the parameter the setting value will be stored.
- ※ Shaded parameters are for standard-level users, the others are for high-level users.
- (You can set the user level in parameter 5 group)
- ※: This parameter might not be displayed depending on other parameter settings.

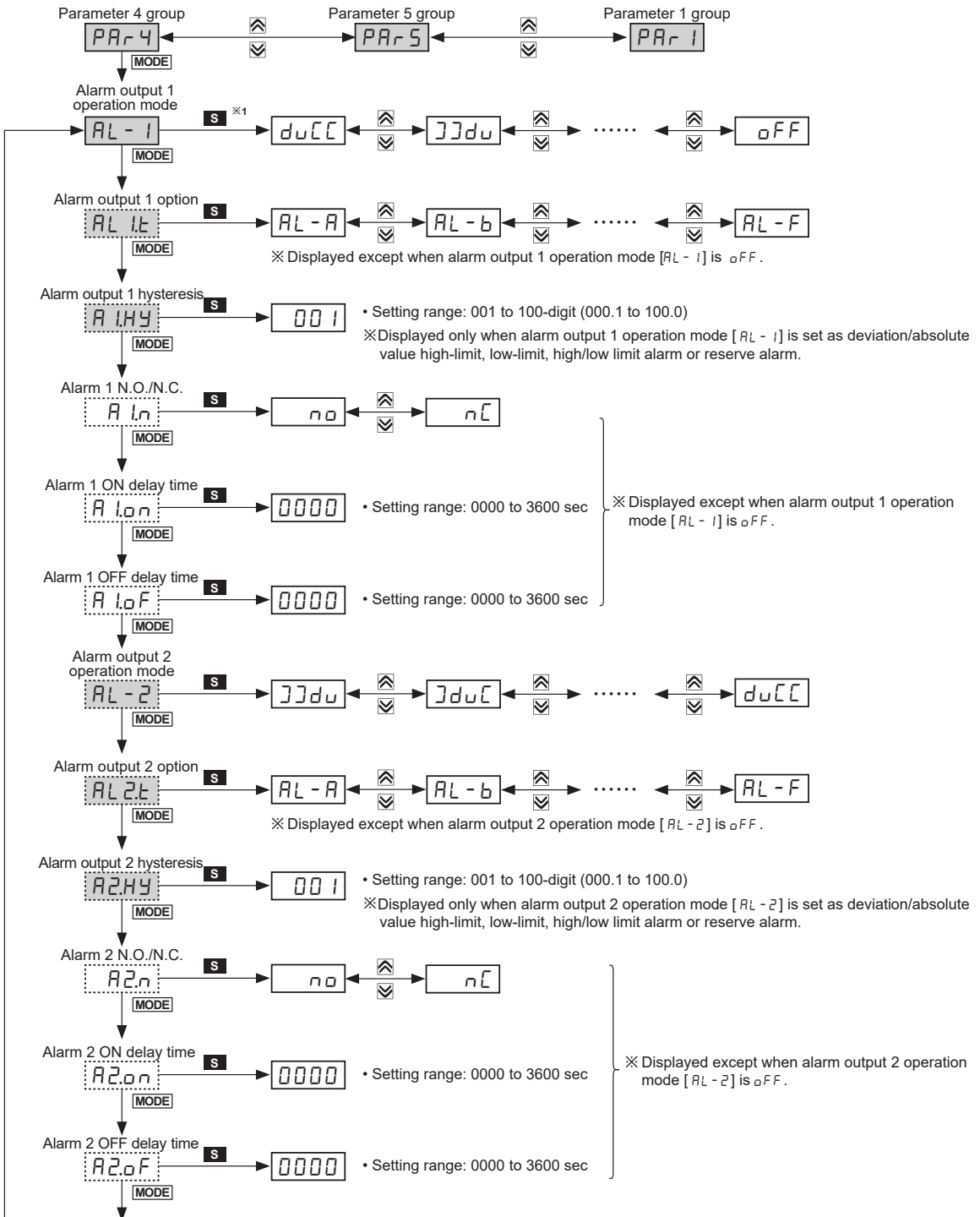

# Bar Graph Temperature Controllers

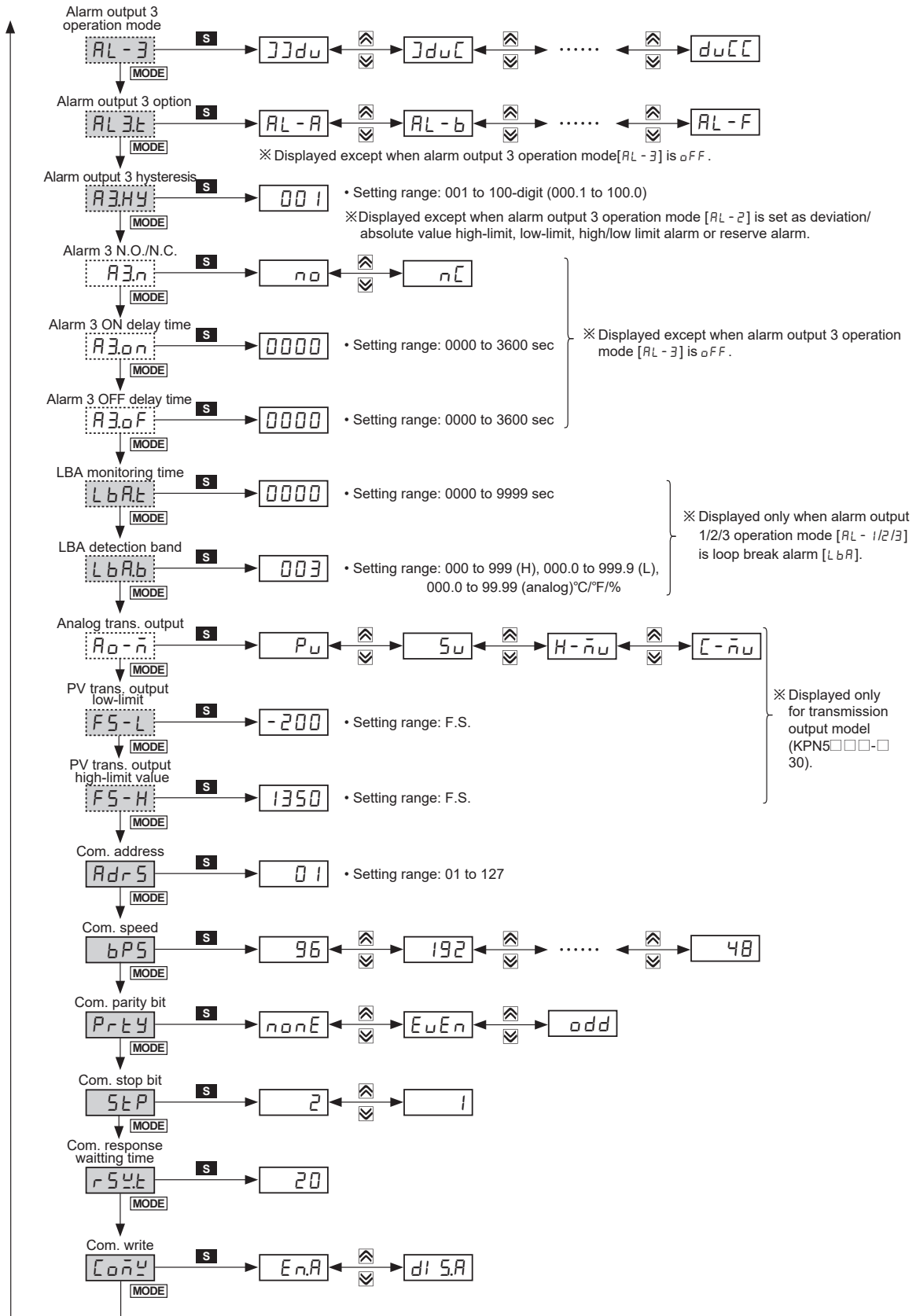

# KPN Series

## Parameter 5 Group

※1: **S**: Press any key among  $\leftarrow$ ,  $\rightarrow$ ,  $\uparrow$ ,  $\downarrow$

※After entering setting mode, press **MODE** key anytime for 3 sec to return to Run mode.

※After entering setting mode, press **MODE** key anytime for 1.5 sec to go to the concerned group name.

※If you press the **MODE** key after changing the setting value of the parameter the setting value will be stored.

※   Shaded parameters are for standard-level users, the others are for high-level users.  
(You can set the user level in parameter 5 group)

※ : This parameter might not be displayed depending on other parameter settings.

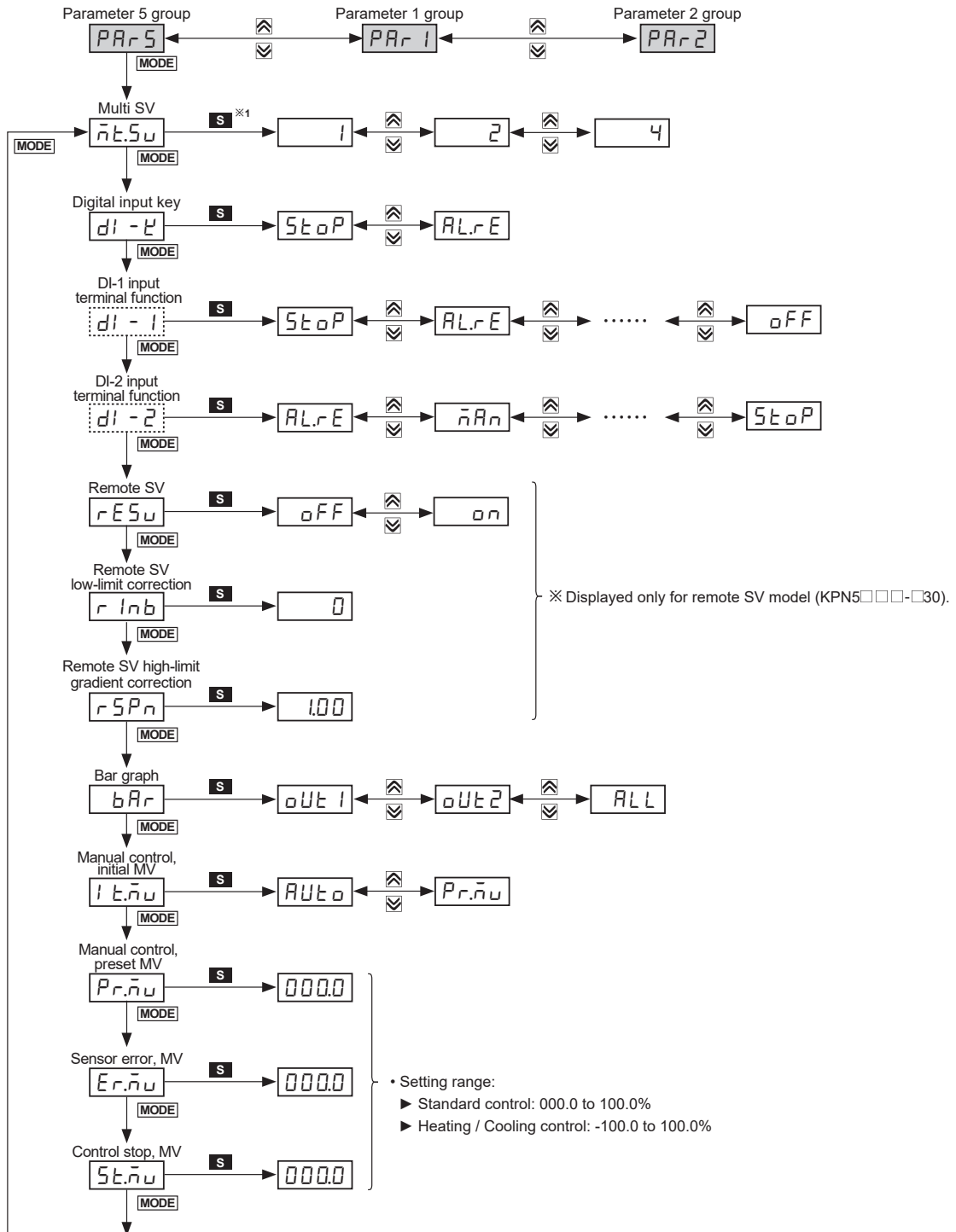

# Bar Graph Temperature Controllers

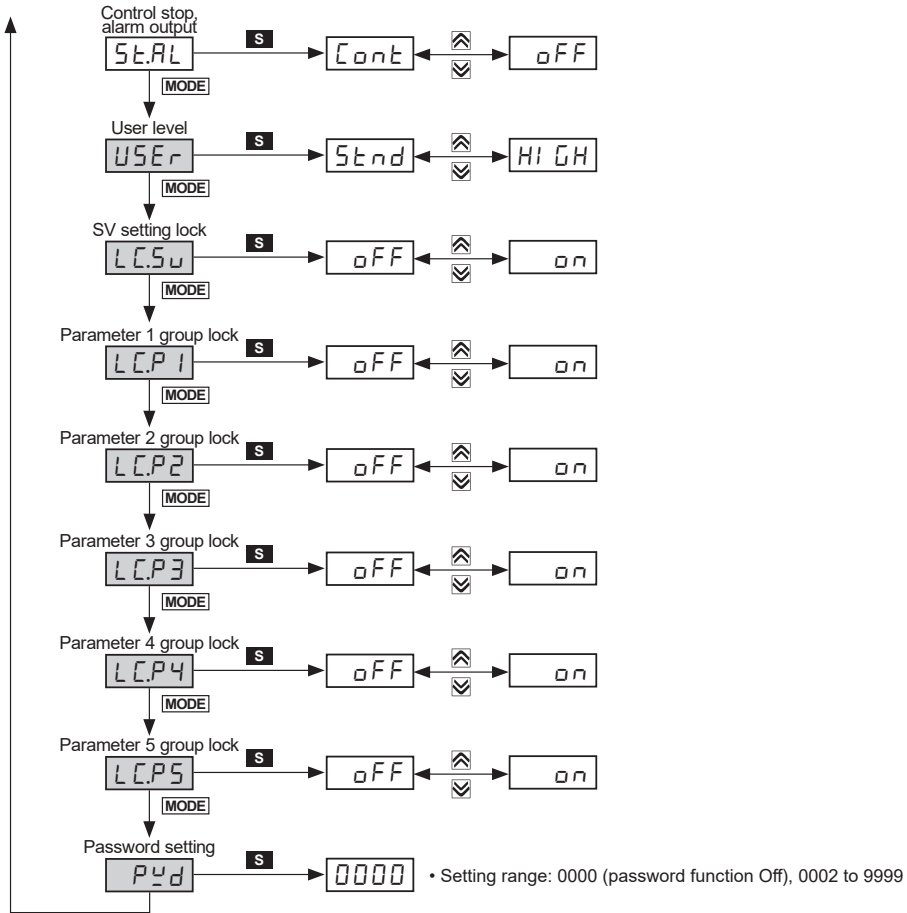

# KPN Series

## ■ Factory Default

### • SV setting [ S<sub>v</sub> ]

Parameter	Default
S <sub>v</sub>	0

### • Password input parameter

Parameter	Default
PASS	0001

### • Parameter 1 group [ P<sub>R-1</sub> ]

Parameter	Default	Parameter	Default	Parameter	Default	Parameter	Default
r-S	rUn	AL 1L	1550	AL 3L	0000	S <sub>v</sub> -2	0000
S <sub>v</sub> -n	S <sub>v</sub> -0	AL 1H	1550	AL 3H	0000	S <sub>v</sub> -3	0000
Ct-A	0.0	AL 2L	1550	S <sub>v</sub> -0	0000		
AL 1L	1550	AL 2H	1550	S <sub>v</sub> -1	0000		

### • Parameter 2 group [ P<sub>R-2</sub> ]

Parameter	Default	Parameter	Default	Parameter	Default	Parameter	Default
At	oFF	H-d	0000	H.oSt	000	rARU	000
H-P	0 10.0	C-d	0000	C.HYS	002	rARd	000
C-P	0 10.0	db	0000	C.oSt	000	r.Unt	nI n
H-1	0000	rESt	050.0	L-nu	-100.0		
C-1	0000	H.HYS	002	H-nu	100.0		

### • Parameter 3 group [ P<sub>R-3</sub> ]

Parameter	Default	Parameter	Default	Parameter	Default	Parameter	Default
in-t	2CRH	H-5C	100.0	o-Ft	HEAt		55r
Unl-t	°C	dUnl-t	°Po		H-C	o 1.nA	4-20
L-rG	00.00	in-b	0000	C-n-d	PI d	oUt2	55r
H-rG	10.00	nARF	000.1		PP	o2.nA	4-20
dot	0.0	L-Su	-200	At-t	tUnl	H-t	020.0 (Relay)
L-5C	000.0	H-5u	1350	oUt 1	rLY	C-t	000.0 (SSR drive)

### • Parameter 4 group [ P<sub>R-4</sub> ]

Parameter	Default	Parameter	Default	Parameter	Default	Parameter	Default	Parameter	Default
AL-1	duCC	AL-2	JJdu	AL-3	LbA	LbAt	0000	bPS	96
AL 1t	AL-A	AL 2t	AL-A	AL 3t	AL-A	LbAb	002	Prty	nonE
ALHY	001	A2HY	001	A3HY	001	Ro.n	Pu	StP	2
ALn	no	A2n	no	A3n	no	FSL	-200	rSYt	20
ALon	0000	A2on	0000	A3on	0000	FSH	1350	Co.nY	EnA
ALoF	0000	A2oF	0000	A3oF	0000	Adr5	01		

### • Parameter 5 group [ P<sub>R-5</sub> ]

Parameter	Default	Parameter	Default	Parameter	Default	Parameter	Default
nE.Su	1	rSPn	1000	St.nu	0000	LCP3	oFF
dl-2	StoP		oUt 1	St.AL	COnE	LCP4	oFF
dl-1	oFF	bAR	ALL	USEr	Stnd	LCP5	oFF
dl-2	oFF	1E.nu	AUto	LCSu	oFF	PYd	0000
rESu	oFF	Pr.nu	0000	LCP1	oFF		
rInb	0000	Er.nu	0000	LCP2	oFF		

※ Shaded parameters are factory defaults for the heating & cooling model.

# Bar Graph Temperature Controllers

## ■ Communication Output

It is for parameter setting and monitoring via external devices (PC, PLC, etc.).

### • Interface

Comm. protocol	Modbus RTU (Character = 11-bit fixed)	Comm. speed	2400, 4800, 9600, 19200, 38400 bps
Connection type	RS485	Comm. response wait time	5 to 99ms
Application standard	Compliance with EIA RS485	Start bit	1-bit (fixed)
Max. connections	31 units (address: 01 to 127)	Data bit	8-bit (fixed)
Synchronous method	Asynchronous	Parity bit	None, Even, Odd
Comm. method	Two-wire half duplex	Stop bit	1, 2-bit
Comm. distance	Within max. 800m		

※It is not allowed to set overlapping communication address at the same communication line.  
Use twisted pair wire for RS485 communication.

### • Application of system organization

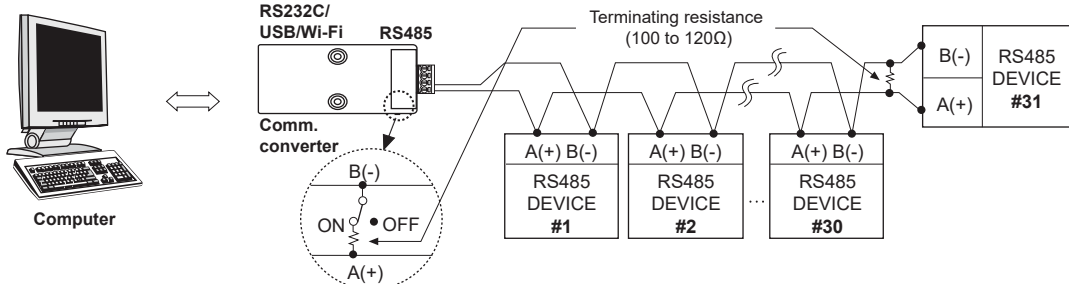

※It is recommended to use Autonics communication converter; SCM-WF48 (Wi-Fi to RS485·USB wireless communication converter, sold separately), SCM-US48I (USB to RS485 converter, sold separately), SCM-38I (RS232C to RS485 converter, sold separately), SCM-US (USB to Serial converter, sold separately).  
Please use twisted pair wire, which is suitable for RS485 communication, for SCM-WF48, SCM-US48I and SCM-38I.

# KPN Series

## ■ Functions

### ◎ Alarm operation

※ H: alarm output □ hysteresis [R□HY]

Mode	Name	Operation	Description
OFF	—	—	No alarm output
dH	Deviation high-limit alarm	<p>High deviation: Set as 10°C      High deviation: Set as -10°C</p>	If deviation between PV and SV as high-limit is higher than set value of deviation temperature, the alarm output will be ON.
dL	Deviation low-limit alarm	<p>Low deviation: Set as 10°C      Low deviation: Set as -10°C</p>	If deviation between PV and SV as low-limit is higher than set value of deviation temperature, the alarm output will be ON.
dHL	Deviation high/low-limit alarm	<p>Low deviation: Set as 10°C, High deviation: Set as 20°C</p>	If deviation between PV and SV as high/low-limit is higher than set value of deviation temperature, the alarm output will be ON.
dHLR	Deviation high/low-limit reserve alarm	<p>Low deviation: Set as 10°C, High deviation: Set as 20°C</p>	If deviation between PV and SV as high/low-limit is higher than set value of deviation temperature, the alarm output will be OFF.
PVH	Absolute value high limit alarm	<p>Absolute value alarm: Set as 90°C      Absolute value alarm: Set as 110°C</p>	If PV is higher than the absolute value, the output will be ON.
PVL	Absolute value low limit alarm	<p>Absolute value alarm: Set as 90°C      Absolute value alarm: Set as 110°C</p>	If PV is lower than the absolute value, the output will be ON.
LbR	Loop break alarm	—	It will be ON when it detects loop break.
SbR	Sensor break alarm	—	It will be ON when it detects sensor disconnection.
HbR	Heater break alarm	—	It will be ON when CT detects heater break.

### ◎ Alarm option

Mode	Name	Description
RL - A	Standard alarm	If it is an alarm condition, alarm output is ON. If it is a clear alarm condition, alarm output is OFF.
RL - b	Alarm latch	If it is an alarm condition, alarm output is ON and maintains ON status.
RL - C	Standby sequence 1	First alarm condition is ignored and from second alarm condition, standard alarm operates. When power is supplied and it is an alarm condition, this first alarm condition is ignored and from the second alarm condition, standard alarm operates.
RL - d	Alarm latch and standby sequence 1	If it is an alarm condition, it operates both alarm latch and standby sequence. When power is supplied and it is an alarm condition, this first alarm condition is ignored and from the second alarm condition, alarm latch operates.
RL - E	Standby sequence 2	First alarm condition is ignored and from second alarm condition, standard alarm operates. When re-applied standby sequence and if it is alarm condition, alarm output does not turn ON. After clearing alarm condition, standard alarm operates.
RL - F	Alarm latch and standby sequence 2	Basic operation is same as alarm latch and standby sequence 1. If it operates not only by power ON/OFF, but also alarm setting value, or alarm option changing. When re-applied standby sequence and if it is alarm condition, alarm output does not turn ON. After clearing alarm condition, alarm latch operates.

※ Condition of re-applied standby sequence for standby sequence 1, alarm latch and standby sequence 1: Power ON  
 Condition of re-applied standby sequence for standby sequence 2, alarm latch and standby sequence 2: Power ON, changing set temperature, alarm temperature[RL 1, RL 2] or alarm operation [RL - 1, RL - 2], switching STOP mode to RUN mode.

# Bar Graph Temperature Controllers

## ■ Functions

### ◎ Control output mode [ $\alpha$ -Ft ]

- Control output modes for general temperature control include heating, cooling, and heating/cooling.
- Heating control (reverse operation) and cooling control (normal operation) are mutually opposing operations with inverse outputs.
- The PID time constant varies based on the controlled objects during PID control.

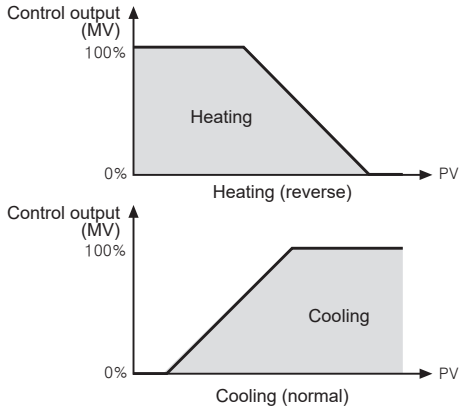

Group	Parameter	Setting range	Default	Unit
PAR3	$\alpha$ -Ft	Standard model HEAt/COL	HEAt	—
		Heating & Cooling mode HEAt/COL/H-C	H-C	—

### ◎ Heating control [ HEAt ]

The output will be provided in order to supply power to the load (heater) if PV(present temperature) falls below SV(set temperature).

### ◎ Cooling control [ COL ]

The output will be provided in order to supply power to the load (cooler) if PV(present temperature) rises above SV (set temperature)

### ◎ Heating/Cooling control [ H-C ]

Heating and Cooling with a controller when it is difficult to control subject temperature with only heating or cooling. Heating and cooling control mode controls the object using different PID time constants for each heating and cooling. It is also possible to set heating and cooling control in both PID control or ON/OFF control mode. Heating/cooling output can be selected among Relay output, SSR drive output and current output depending on model types chosen according to your application environment. (Note that only standard SSR control is available for SSR drive output in OUT2.)

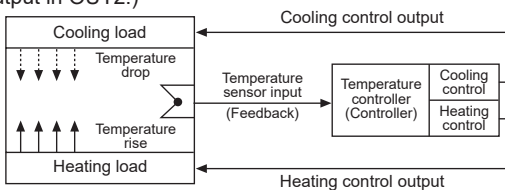

- For heating and cooling control, OUT1 control output is dedicated to heating control and OUT2 control output to cooling control.

### ◎ Auto-tuning [ At ]

In PID control, auto-tuning processes the control subject's thermal characteristics and thermal response rate at the controller, and then determines the necessary PID time constant. Application of the PID time constant realizes fast response and high precision temperature control.

- Auto-tuning automatically stores PID time constants upon termination. These PID time constants can then be modified by the user to suit their usage environment.
- When auto-tuning is in progress, the AT lamp located on the front of the controller flashes in 1 second intervals. When auto-tuning finishes, the AT lamp automatically goes off and the auto-tuning parameter will return to OFF.

SV	Description
$\alpha$ FF	Auto-tuning stops
$\alpha$ n	Auto-tuning starts

Group	Parameter	Setting range	Default	Unit
PAR2	At	$\alpha$ FF/ $\alpha$ n	$\alpha$ FF	—

- Manual interruption or a sensor break error when auto-tuning is in progress restores the PID time constant to the value used prior to the auto-tuning session.
- Auto-tuning continues to run even if the temperature reading exceeds or falls below the input range.
- When auto-tuning is in progress, parameters can only be referenced and not altered.
- Auto-tuning is not available in manual control. (Manual Control).

### ◎ Control output (OUT1/OUT2) selection [ OUT1 / OUT2 ]

- The 1 output type (OUT1) model supports relay output, current output, SSR drive output.
- The 2 output type (OUT1, OUT2) model supports relay output fixed or current output, SSR drive output.

### ◎ Parameter mask

This function is able to hide unnecessary parameters to user environment or less frequently used parameters in parameter setting group. You can set this in the comprehensive device management program (DAQMaster). Though masked parameters are not displayed in parameter setting group, the parameter setting values are applied. For more information, refer to the DAQMaster user manual. Visit our website ([www.autonics.com](http://www.autonics.com)) to download the DAQMaster program and the user manual.

<Before applying mask>

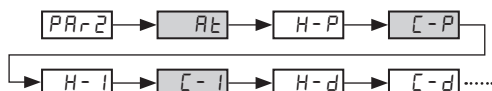

<After applying mask>



The above is masking auto tuning [ At ], cooling proportional band [ C-P ], cooling integral time [ C-I ], cooling derivative time [ C-d ] parameters in parameter 2 group.

## ■ Functions

### ◎ User parameter group [PAr-U]

This function is able to set the frequently used parameters to the user parameter group.

You can quickly and easily set parameter settings. User parameter group can have up to 30 parameters in the comprehensive device management program (DAQMaster.) Visit our website (www.autonics.com) to download the DAQMaster program and the user manual.

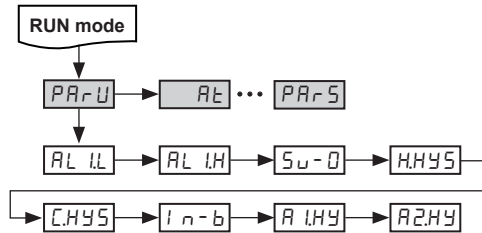

The above is setting user parameter group in the DAQMaster with alarm output 1 low-limit value [AL L], alarm output 1 high-limit value [AL H], SV-0 set value [SV-0] parameters of parameter 1 group, heating hysteresis [HYS], cooling hysteresis [CHYS] parameters of parameter 2 group, input correction [I n-b], parameter of parameter 3 group, alarm output 1 hysteresis [AL H], alarm output 2 hysteresis [RHYS] parameters of parameter 4 group.

### ◎ Bar graph

MV of control output (OUT1, OUT2) is displayed as the bar graph in real-time. According to bar graph setting [bAr] in parameter 5 group, it displays bar graph by control output or does not display it.

OUT1 (red LED)  
OUT2 (green LED)

One LED is 10% (total 10 LEDs: 100%). If control output MV is 0.1 to 10%, one LED turns ON. If MV is 90.1 to 100%, 10 LEDs turn ON.

The 1 output type (heating or cooling control) model has one OUT1 bar graph (red).

The 2 output type (heating & cooling control) model has two bar graphs; OUT1 bar graph (red), OUT2 bar graph (green). OUT1 is for heating MV and OUT2 is for cooling MV.

### ◎ Remote SV setting

This function is to set SV by inputting analog (DC4-20 mA, 1-5 VDC) signal to no. 13 and 14 terminals. (Set that remote SV [rESV] is ON in parameter 5 group) Input analog signal is changed to between SV low-limit value [L-SV] to SV high-limit value [H-SV].

※ When using remote SV, you cannot select SV setting by front keys and multi SV setting by digital input.

### ◎ Parameter initialization

It initializes all parameters to factory default values. Press the front 1+4+3 keys for 5 sec at the same time and [r n t] parameter is displayed. Select 'YES' to initialize all parameters.

If the password is set, you must enter the password. After initializing the parameters, the password parameter is also initialized.

※ Refer to the KPN user manual for more functions.

## ■ Proper Usage

### ◎ Simple troubleshooting for process controller

- **When the load (Heater etc) is not operated** Please check operation of the out indicator located in front panel of the unit. If the indicator does not operate, please check the parameter of all programmed mode. If the indicator is operating, please check the output (Relay, SSR drive, DC4-20mA current) after separating output line from the unit.
- **When it displays aPEN during operation** This is a warning that external sensor is cut off (open). Please turn off power and check the state of sensor. If sensor is not cut off (open), disconnect sensor line from terminal block and +, - together. When you turn on power it can check room temperature. If this unit cannot indicate room temperature, this unit itself is faulty. Please remove this unit from equipment and service or replace. (When the input mode is thermocouple, it is available to indicate room temperature.)
- **In case of indicating "Error" in display** This Error message is indicated in case of damaging inner chip program data by outer strong noise. In this case, please send the unit to our after service center after removing the unit from system. Noise protection is designed in this unit, but it does not stand up strong noise continuously. If bigger noise than specified (Max. 2kV) flows in the unit, it can be damaged.

### ◎ Cautions during Use

- Follow instructions in 'Cautions during Use'. Otherwise, It may cause unexpected accidents.
- Check the polarity of the terminals before wiring the temperature sensor. For RTD temperature sensor, wire it as 3-wire type, using cables in same thickness and length. For thermocouple (CT) temperature sensor, use the designated compensation wire for extending wire.
- Keep away from high voltage lines or power lines to prevent inductive noise. In case installing power line and input signal line closely, use line filter or varistor at power line and shielded wire at input signal line. Do not use near the equipment which generates strong magnetic force or high frequency noise.
- Do not apply excessive power when connecting or disconnecting the connectors of the product.
- Install a power switch or circuit breaker in the easily accessible place for supplying or disconnecting the power.
- Do not use the unit for other purpose (e.g. voltmeter, ammeter), but temperature controller.
- When changing the input sensor, turn off the power first before changing. After changing the input sensor, modify the value of the corresponding parameter.
- Do not overlapping communication line and power line. Use twisted pair wire for communication line and connect ferrite bead at each end of line to reduce the effect of external noise.
- Make a required space around the unit for radiation of heat. For accurate temperature measurement, warm up the unit over 20 min after turning on the power.
- Make sure that power supply voltage reaches to the rated voltage within 2 sec after supplying power.
- Do not wire to terminals which are not used.
- This unit may be used in the following environments.
  - ① Indoors (in the environment condition rated in 'Specifications')
  - ② Altitude max. 2,000m
  - ③ Pollution degree 2
  - ④ Installation category II